

Thank you for purchasing the Lyra Erodion Moving Coil Step-Up Interface (MC step-up transformer), made by Lyra Co., Ltd. of Tokyo, Japan. Please observe these instructions carefully.

The Erodion is especially designed for Lyra cartridges, but will also fit other low-impedance cartridges of 2 - 10 ohms. With a gain of 26 dB the Erodion has been designed to step the output of low output, low impedance MC cartridges up to standard 10 kohms ~ 47 kohms MM phono inputs of preamplifiers and phono stages.

An MC step-up transformer fundamentally works very different from an amplification stage. When a low-impedance MC cartridge is connected directly to a high gain RIAA preamplifier, the impedance loading value can be set to any value between 100 ohms to 47 kohms. However, an MC step-up transformer is designed as an impedance matching device between an MC cartridge and a 10 kohms ~ 47 kohms MM level RIAA input. For this reason an MC step-up transformer should only be used with MC cartridges within the limited impedance range it has been designed for. Significant deviation from the specified range will result in a different impedance ratio, and also an altered perceived frequency balance.

The general Lyra policy has been, and still remains, to recommend connection of Lyra MC cartridges directly to high quality, high sensitivity RIAA preamplifier inputs that are capable of amplifying a 0.2 - 0.6mV MC signal without any disturbing noise being added to the sound. However, some preamplifiers with an MM level RIAA stage may not be capable of this task, but otherwise sound wonderful. The combination of a step-up transformer mated to an MM-level RIAA input can also create a sound with a feeling of great energy and solidity, which can be extremely enjoyable.

The Erodion was intended to enable high-quality MM-level RIAA stages to be used with low-impedance MC cartridges, but was also designed to sound as open and transparent as possible. We believe the Erodion fills the need for a high-performance MC transformer which should please the most discerning analog connoisseur.

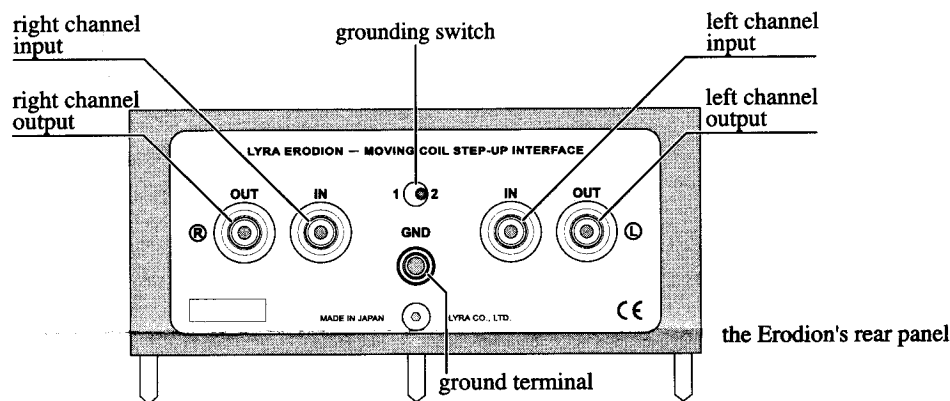

Handling instructions:

1. Turn off your power amplifier, preamplifier or phono stage before you connect the Erodion.
2. The Erodion has been designed solely for use with low-impedance MC cartridges of 2 - 10 ohms at its inputs. Its outputs should be connected to standard MM level RIAA phono inputs of 10 kohms ~ 47 kohms load.
3. Use high quality, low capacitance interconnect cables with male RCA connectors for connecting the Erodion to turntable and preamplifier respectively. The Erodion will perform at its best if the interconnects between it and the phono stage are as short as possible.
4. Carefully follow the markings above each female RCA connector on the Erodion's rear panel when connecting. Connect the tonearm cable to the inputs (IN) towards the center of the Erodion's back panel. Make sure the right channel (usually marked red) is connected to the (R) side labeled with red lettering, and the left channel (usually marked black) to the (L) side of the transformer (with blue lettering). Connect the Erodion's outputs (OUT) to your preamplifier's or phono stage's MM RIAA inputs. Carefully follow markings that show right and left channel.
5. The normal way of grounding an MC transformer is to connect the grounding wire from the tonearm or turntable to the GND terminal of the MC transformer, and also to connect another grounding wire (any insulated copper wire you have available) between the preamplifier/phono-stage's GND terminal and the MC transformer's GND terminal.

However, for better sound, LYRA recommends that grounding is kept floating as much as possible.

The Erodion is equipped with a grounding switch labeled (1) and (2).

The (1) position is for chassis ground connected, while the (2) position is for floating ground.

- (a) Please follow the following procedure for connecting grounding wires to the Erodion. At first; do NOT connect any grounding wire to the Erodion. Make sure the Erodion's grounding switch has been set to the (2) position (floating ground). Turn on your preamplifier/phono stage and also your power amplifier. Switch your preamp to the phono position and, with the volume turned half-way up, listen for any hum through your speakers. If hum is audible, move the grounding switch to the (1) position to see if the hum persists, is acceptably quiet, or absent.
- (b) If you hear hum, please connect the tonearm/turntable's grounding wire to the preamplifier/phono-stage's GND terminal. First set the Erodion's grounding switch to the (2) floating ground position. If hum remains audible, move the grounding switch to the (1) position to see if the hum persists, is acceptably quiet, or absent.
- (c) If you still hear hum, try disconnecting the tonearm/turntable's grounding wire from the preamplifier/phono stage's GND terminal and attach it to the Erodion's GND terminal. Keep the Erodion's grounding switch in the (2) floating ground position. If hum remains audible, try to move the Erodion's grounding switch to the (1) position to see if the hum persists, is acceptably quiet, or absent.

(d) If you still hear hum, connect an additional grounding wire (any insulated copper wire you have available) between the preamplifier/phono-stage's GND terminal and the Erodion's GND terminal while the tonearm/turntable's grounding wire remains connected to the Erodion's GND terminal and the Erodion's grounding switch in the (2) position. If hum remains audible, try to move the Erodion's grounding switch to the (1) position to see if the hum persists, is acceptably quiet, or absent.

Always remember that Lyra's recommendation for the Erodion is to keep the grounding switch in the (2) floating ground position as much as possible, and to use as little grounding for it as possible. Only do the minimum necessary to reduce the hum to an acceptable level. Rather than immediately attempting to shut out all hum by connecting all grounding wires and setting the grounding switch to the (1) grounded position, sometimes better sound will be obtained in the (2) floating ground position, even with a small level of hum still present.

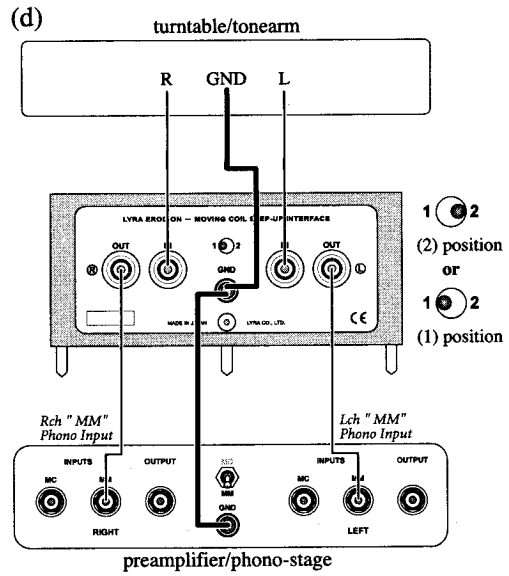
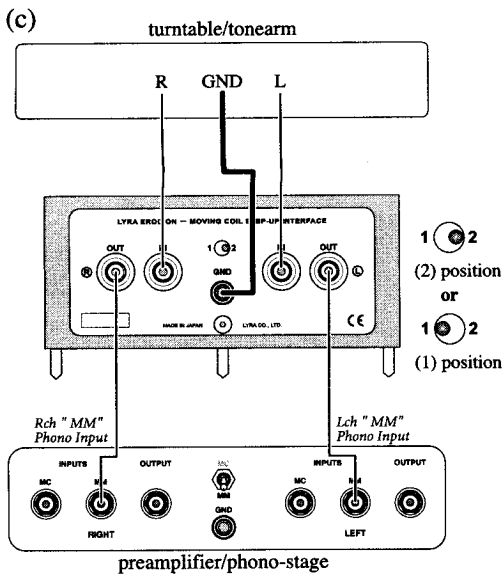
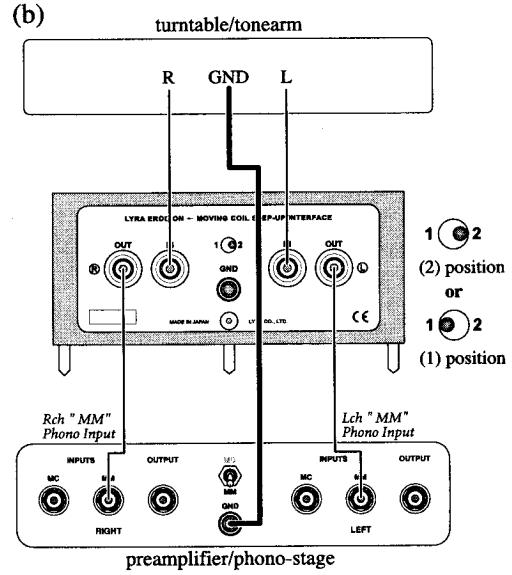
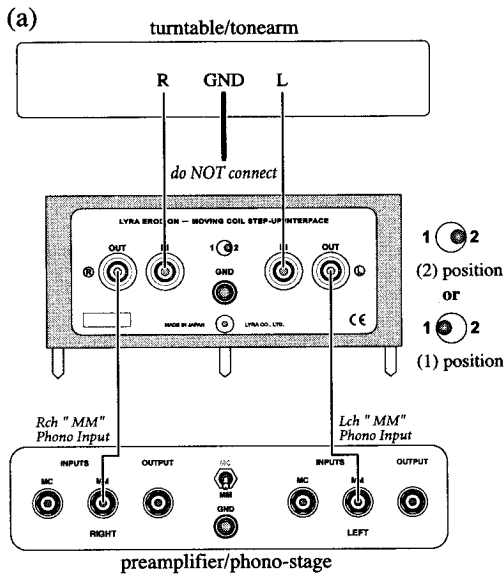

6. The physical location of the Erodion will also have a significant effect on hum levels. It is recommended to move the Erodion around until the optimal, quietest location is found.

7. Never attempt to use any apparatus to measure across the Erodion's connectors. Failure to observe this warning could lead to magnetization of the transformer core resulting in reduced performance.

8. Never attempt to attach any electrical power supply to the Erodion.

Specifications:

- * Gain: 26 dB (20 times) (when cartridge's internal impedance is 2 - 10 ohms and MM level RIAA preamplifier or phono stage presents 47 kohms load)
- * Necessary load of MM RIAA preamplifier or phono stage: 10 kohms ~ 47 kohms
- * Useable MC phono cartridges: internal impedance range of 2 ohms - 10 ohms
- * Frequency range: 10 - 100,000 Hz (when above conditions are met)
- * Feet: three stainless steel spikes
- * Net size: (W x D x H) 150 mm x 115 mm (128 mm incl. connectors) x 65 mm (78 mm incl. feet)
- * Net weight: 2430 grams
- * Size of package: (W x D x H) 185 mm x 146 mm x 90 mm
- * Gross weight incl. package: 2640 grams
- * This product does not contain any electrical power supply, and it does not require any power input of any kind.